

## Engaging Students with Course Project Development: An Active Learning Element for a *System Dynamics* Course

Jason Yao

*Department of Engineering, College of Engineering and Technology, East Carolina University, Greenville, NC 27858*

### Abstract

*System Dynamics* is a senior level course for the Mechanical Engineering Concentration of a general engineering program at Campbell University's newly created School of Engineering. Course objectives include the application of mathematical methods for system dynamics analysis and design, as well as that of simulation tools (e.g., MATLAB and SIMULINK). A comprehensive course project with a real-world application context has been planned to provide students with the opportunity to apply all the mathematical and computational skills they learned through the semester. After being exposed with the basics of the theory and tools, students were asked to research and propose their own course projects. This paper introduces this active learning experience from its planning to implementation and assessment. It also presents lessons and improvement opportunities that can enhance the learning experience in the future.

### Keywords

Active Learning, Dynamic Systems, Modeling

### Introduction

The Mechanical Engineering concentration at Campbell University is, as like in all other programs, the largest concentration in a general engineering program. The senior-level course, *System Dynamics*, aims to equip students with necessary mathematical and computational skills and the process for modeling the dynamic behaviors of physical systems. The course incorporated several **active-learning** experiences (ALE), such as those suggested in [1]. For example, after the instructor led the study of mechanical and electrical systems in the first two weeks of the semester, students were challenged to lead discussion of thermal and fluid systems (which further divided in hydraulic and pneumatic systems). Feedback received from students was extremely positive.

The second major ALE element is a **project-based learning** (PBL) experience. As elaborated here, this PBL experience challenged students with the need to integrate physics, math, modeling, and computer software tool all into a single application. PBL, as a broadly recognized effective approach [2-6], maximizes students' interest and curiosity, therefore encouraging active learning [7]. In this practice, the students, as groups of two or three, were given the opportunity to define/choose project ideas of their own interest. While the practices presented here certainly benefited students similar to other PBL practices in literatures [8-10], the paper avoids restating (or validating) those well-documented points and benefits. It instead highlights the successes and

lessons from the unusually “open” (or flexible) student-defined projects with real-world significance. Keeping design ideas open and allowing students the decision/control of their own ideas could be risky, or cause considerable uncertainty, at least for the instructor. The attempt and the overall success described in the paper demonstrate that such an approach is in fact feasible and desired by students.

The following sections start with a brief introduction of the course and the major topic areas covered in the adopted textbook. It then quickly moves to the implementation of the project-based learning experience, followed by several noteworthy findings from the trial. The paper concludes by a summary of the successes and future improvements.

### **The MECH440 *System Dynamics* Course**

This senior mechanical engineering course is where students gain full appreciation of how mathematical methods can be used to describe, and if desired, to control the dynamics of many physical systems. The course revisits the physics required to perform engineering analysis on mechanical systems (e.g., a typical example is spring-mass-damper, a.k.a. SMD, systems), electrical circuits (e.g., resistor-inductor-capacitor, or RLC, system), fluid systems (e.g., tank levels), and thermal systems (e.g., heat exchanger). It also serves the single point to expose mechanical engineering students with important aspects of feedback control, namely system performance, stability issues, and PID (proportional, integral, and derivative) controllers. Upon completion of the course, students are expected to achieve eight learning objectives. Only those that are relevant to the active project learning are listed below:

- *Formulate mathematical models for mechanical, electrical, fluid, and thermal systems.*
- *Formulate the frequency response of linear dynamic systems.*
- *Perform computer simulation of various dynamic system responses.*
- *Apply time and frequency response analyses to system identification and design.*
- *Understand dynamic system stability and transient response specifications.*

A thorough study in summer 2019 identified an ideal textbook for the course [11], which covers dynamics of systems progressing from specific physical systems, to forms of mathematic representations, to analysis in time- and frequency-domain (see Figure 1). This natural flow facilitates student understanding and allows the implementation of several major active learning elements. For example, the instructor first developed SIMULINK models of mechanical and electrical systems with a three-step process shown in Figure 2. Students were then asked to repeat the same process, and use textbook resources to present the modeling of thermal and fluid (pneumatic and hydraulic) systems.

### **PBL Methods:**

This topic sequence conveniently allowed students to see the modeling of various systems in the first half of the semester, giving them ample time to brainstorm and find their project idea of interest. A course project was therefore developed with students engaged from the very beginning in defining their projects of interest, with the following requirements that permitted a vast amount of flexibility:

1. *It (the proposed project) must have real-world significance.*
2. *It must be an engineering (i.e., ME, EE, thermal, fluid, hydraulic, pneumatic, or some combination of all these) problem.*
3. *The system modeling must involve differential equation(s).*
4. *It can be modeling, analysis, design, or troubleshooting in nature.*
5. *The scope of the project should be appropriate (we do not want something that can be done in a couple of days but can be finished by the end of the semester).*

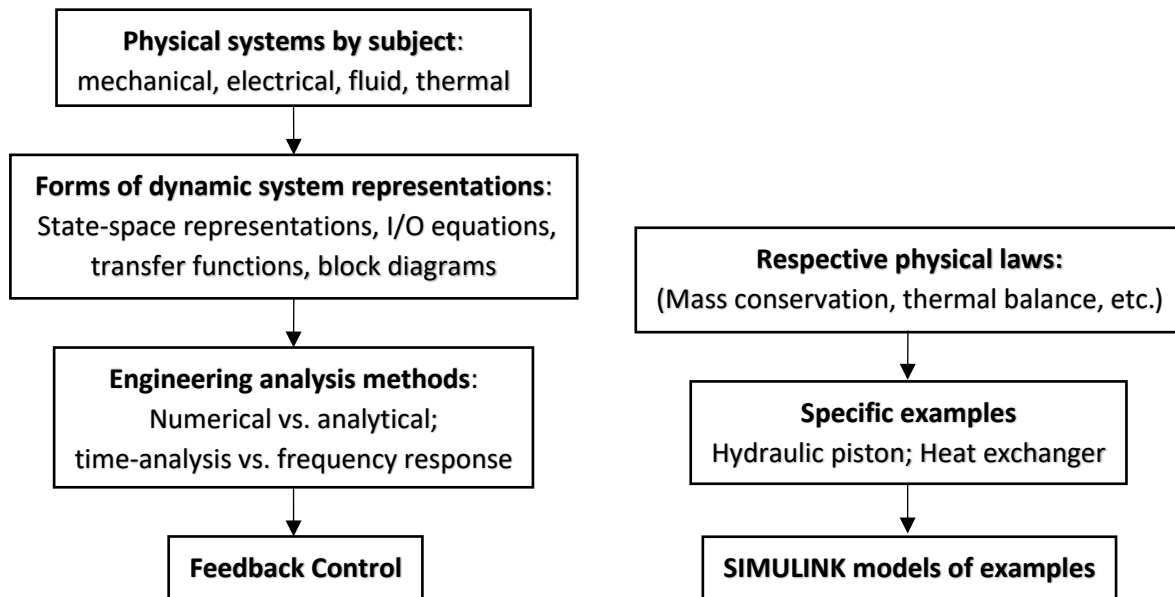

Figure 1. Flow of the topics in the Kluever book.

Figure 2. The three-step introduction for system modeling

To better assist students identifying their project ideas and research questions, several examples were suggested (see list below). If they desire to, students could also refer to the case studies in the last chapter of the textbook, although independently identified and completed project ideas were encouraged with a 20% award to their project grades. Students were only allowed to change their project idea during the first two weeks to ensure they have enough time to complete the required work, and also to manage possible scope creep and reduce uncertainty to grading.

1. Modern elevator technologies: Many high buildings today are equipped with impressively fast and comfortable elevators. How are the motors controlled to make that happen?
2. Vehicle seat suspension system: what will happen if the springs are aged or the hydraulic systems leak?
3. Air-brake system: how would the braking distance change if the pneumatic system leaks or the vehicle is over loaded?
4. Tissue burn: assuming skin is burnt by boiled water then is dipped into cold water to alleviate the wound, how is the depth and/or size of the wound related to the delay and/or the temperature of the cold water?

Multiple checkpoints were set up over the course of five weeks to ensure students make meaningful progresses without procrastinating to the end (see Table I). For example, in the group project proposal due one week after the project was assigned, students were required to clearly address the following aspects:

1. *Why did you select the project?*
2. *What is the real-world significance/why it is important?*
3. *What is the dynamic system in the project?*
4. *What value does or could a dynamic model and analysis bring to the system you choose?*
5. *What are the objectives of the project?*
6. *What are the constraints?*
7. *Develop an initial plan to complete the project.*

Table I. Checkpoints and grade distribution during the course of the project.

Week	Deliverables	Points
1	Group project proposals	10
2	Initial MATLAB/SIMULINK files with progress reports	15
3	Developed MATLAB/SIMULINK files with progress reports	15
4	Fully functioning MATLAB/SIMULINK models	20
5	Final reports and all project (MATLAB/SIMULINK) files	40
TOTAL		100

Students received full credit as long as their proposals addressed all the required areas. Intermediate progresses were evaluated using the rubrics in Appendix I (minor modifications were made for the two checkpoints).

Between Week 4 and Week 5, students were asked to demonstrate their simulations and show their analysis to the instructor. The final project reports were graded using the rubrics in Appendix II. Since this was a group project, group discussion and collaboration of every aspect of the project was expected and encouraged. Their final reports were required to include a section describing how the project load was distributed, how the group collaborated, and how each individual group member contributed.

### **Results:**

A total of 33 students formed thirteen project teams; seven teams had three members and six had two. The ideas that the students decided on after the project definition period are summarized in Table II. Most of the students identified their own problems of interest, with only two teams (four students) deciding to use the case study examples from the textbook. Eight of these projects focused on analyzing dynamic systems of some form, with only one team intending to diagnose and one to design. Fluid, thermal, and other mechanical systems were well presented in these project ideas.

Figure 3 illustrates the modeling of an example project. The project aimed to determine the minimal possible line diameter between two fuel tanks in order to maximize installation convenience under stringent space constraints. Students were able to correctly module the

coupling of the two tanks (Figure 4) and determine the desired line size without the first tank overflowing under normal inflow rate condition.

Table II: Project ideas at a glance.

Team	Title	# in Team	Physical System	Application	Self-identified?
1	Determining the tube diameter to use between tanks for Caterpillar	3	Fluid	Design	Yes
2	Vibration isolation system for a commercial vehicle	2	Mechanical	Analysis	From text
3	Submarine balance	2	Fluid	Analysis	Yes
4	Pressure washer's water velocity vs. nozzle parameters	3	Fluid	Analysis	Yes
5	Desktop computer fan and thermal	3	Thermal	Analysis	Yes
6	Vehicle seat suspension system	2	Mechanical	Analysis	From text
7	Car clutch	3	Fluid	Diagnosis	Yes
8	Dynamics of hydraulic/solenoid piston	2	Fluid/ electrical	Analysis	Yes
9	Hydraulic fluids on the power of construction-based excavator	3	Fluid	Analysis	Yes
10	Modeling of subsystems of a window HVAC unit and coolant fluid comparison	3	Thermal/ Fluid	Analysis	Yes
11	Comparing energy use to boil water with pots of two different materials	3	Thermal	Analysis	Yes
12	Brakes system analysis when a vehicle is overloaded	2	Mechanical	Analysis	Yes
13	Dynamic system education tool	2	Electrical	Design	Yes

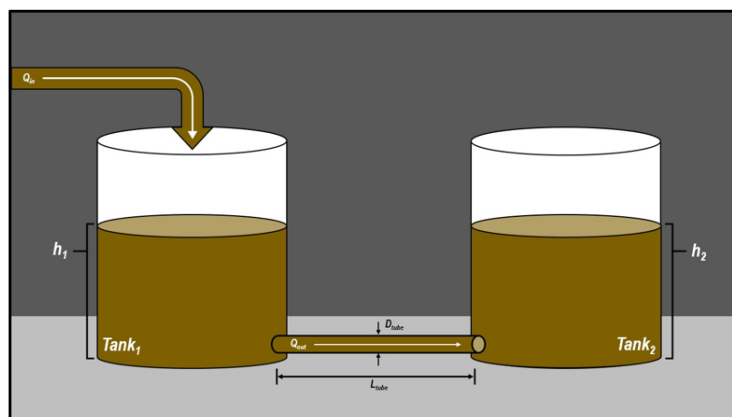

Figure 3. Determining hose size between two coupled tanks.

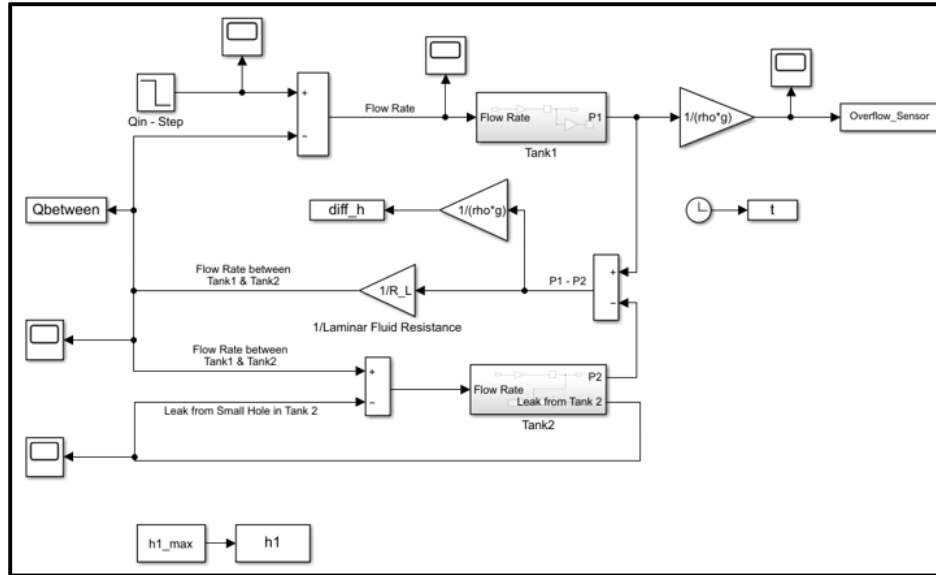

Figure 4. Simulink model of the coupled tanks.

As the last and most important deliverable, the project reports were assigned 40 percent of the total project grade and graded on a forty-point scale. Out of the thirteen teams, the class received an average of 29.94, with a highest team score of 37 and a lowest team score of 18.

## Discussion

This pedagogical experiment was intended to engage students from the beginning so that they could play a more active role in project-based learning. Because this is the first time the course was offered in a new program and there were many moving targets, the instructor was unable to do a more formal, quantitative assessment. Nevertheless, the piloting effort was completed with some noteworthy successes and lessons.

The benefit found from this practice was the presence of an encouraging and motivating environment. The flexibility that students had with defining the project allowed them to research what they believed was interesting. For example, the student who had Project #3 (the submarine balance research) is interested in landing a job with the Marines after graduating. The “Significance” requirement of the assignment pushed students to connect what they learned with real-world applications: several ideas originated either from their jobs or a practical problem that was affecting their daily lives. Project #1, the tube diameter design, was a real problem originating from one of the team members’ summer internships. The student who came up with the car clutch project was recently frustrated by a car with a failed manual transmission. Identifying project ideas with “real-world significance” in mind helps the student to nurture their value-creation mindset.

As shown by the example in the Results section, students were mostly able to use MATLAB/SIMULINK software to the dynamic systems involved in their projects, despite few reports from groups that were able to mathematically present the dynamic characteristics of their

systems with corresponding equations. While not ideal, this can probably be explained as the lack of research experience at the undergraduate level.

The project also brought ample learning experience that was not originally expected. Without prior knowledge of working on such an open-end project, some groups started with an idea that they quickly recognized was unmanageable. One of the interesting examples was Project #10, where the students started with the intention to model individual electric circuit components (capacitors, switches, etc.) involved in an HVAC system, while the overall purpose was the comparing the efficiency of the three refrigerants. The students gradually recognized that they were working at the wrong levels. They were able to move to the appropriate function unit level and eventually focused the study on the thermal and heat-transfer part, with the electrical and mechanical details simplified. Project #3 went through a similar pathway, although the simplification was more towards the geometrics and dimensions of a ship. The knowledge gained about modeling dynamic systems at the proper level, with rational simplification, is surely very valuable for their future engineering profession.

This instructional trial did note several observations that deserve improvements. Particularly, the project needs to be better designed to encourage student confidence and in-depth analysis.

- While most of the students took advantage of the project flexibility and identified their project of “passion”, two of the thirteen groups lacked confidence to step out their comfort zone. Instead of searching for more challenging ideas, they worked conservatively by using existing ideas in the textbook in exchange for a higher likelihood of good grades. This is probably because the students did not have any prior experience with the software tools. Attacking the mathematical modeling of the dynamic system in the project without sufficient MATLAB/SIMULINK skills understandably intimidates students from thinking ambitiously.
- Although all the teams had a generally clear picture about what they wanted to accomplish, only a small number of them ultimately reached their goals. The two students who had Project #13, in particular, did not really understand the objectives. Their work was barely connected to any dynamic modeling, even though they were reminded multiple times during the checkpoint feedback sessions. This feedback was provided orally at the end of face-to-face discussion sessions. In future offering, written comments may be able to address this issue.

## **Conclusion**

This paper reports an effort aiming to engage senior mechanical engineering students in active learning by providing them with the opportunity to identify their own project ideas. The trial did see a satisfactory level of engagement. Most of the students demonstrated their excitement and passion while starting off the project. The project, however, can benefit from several improvements. More thorough introduction to and extensive practice of MATLAB/SIMULINK should be able to boost students’ confidence about dynamic system modeling and embolden them to discover project ideas outside the textbook and try to earn the extra credits. It is also believed that providing written feedback at different project checkpoints can ensure students fully understand the comments they receive, which will help them steer their projects in the right

direction. Lastly, student feedback and quantitative learning outcome data will be collected and assessed in future offerings.

## References:

1. R. M Felder, and R. Brent. “The intellectual development of science and engineering students, Part 2: Teaching to promote growth,” *Journal of Engineering Education*, 93(4), 279-291.
2. J. Mills and D. Treagust. “Engineering education—Is problem-based or project-based learning the answer?” *Australasian Journal of Engineering Education*, 3 (2), 2-16
3. S. Yuan and Z. Shen. “Study and Application of PBL in a Control System Course.” *2nd Intl Conf. on Consumer Electronics, Communications and Networks*, 2012. Yichang, China. Pp. 74 – 2877.
4. Hadim and Esche. “Enhancing the Engineering Curriculum through project-based learning” in *Proc. of 32nd ASEE/IEEE Frontiers in Education Conference*, Boston, MA, USA
5. Feisel, L.D. and A.J. Rosa. “The Role of the Laboratory in Undergraduate Engineering Education”. *Journal of Engineering Education*, 2005. 94(1): p. 121-130.
6. D. R. Woods. “Problem-based learning for large classes in chemical engineering.” In L. Wilkerson & H. Gijsselaers (Eds.), *Bringing problembased learning to higher education* (pp. 91-99). San Francisco, CA: Jossey-Bass.
7. R. M., Lima, D. Carvalho, et al., “A case study on project led education in engineering: students’ and teachers’ perceptions,” *European Journal of Engineering Education*, 32:3, pp. 337 – 347
8. J. Yao, and L. Limberis. “A Project-Driven Approach to Teaching Controls in a General Engineering Program.” *the 2008 Annual American Society of Engineering Education Conference*, Pittsburg, MA, USA.
9. S. Palmquist. “Active project-based learning in structural analysis: Field inspection of steel truss bridge.” *American Society for Engineering Education*, Honolulu, HI.
10. R. M. Lima, P. Andersson, and E. Saalman. “Active Learning in Engineering Education: a (re)introduction,” *European Journal of Engineering Education*, Volume 42, 2017
11. Craig A. Kluever. *Dynamic Systems: Modeling, Simulation, and Control*, 1st Edition. ISBN: 978-1118289457
12. Mathworks. *MATLAB/SIMULINK examples*. <https://www.mathworks.com/help/simulink/examples.html>

## Jason Yao

Dr. Jianchu (Jason) Yao is a Professor and the Associate Dean for Academic Affairs of the College of Engineering and Technology at East Carolina University (ECU), Greenville, North Carolina. He received his Ph.D. degree in Electrical Engineering from Kansas State University in 2005, after which he joined ECU as a founding faculty member of Department of Engineering. His research interests include novel applications of biosensors for non-hospital settings and laboratory/project-driven engineering learning. Dr. Yao is an IEEE senior member and long-time volunteer. He is an energetic advocate for science, technology, engineering, and mathematics (STEM) career development, leading numerous initiatives for the IEEE Eastern North Carolina Section and North Carolina Society for Engineers.



2022 ASEE Southeastern Section Conference

**Appendix I: Project progress checkpoint rubrics:**

	0	1	2	3	Category points	Earned points
<b>Amount of work done</b>	Nothing done	Minimum amount	Acceptable progress	Exceed expectation	4	
<b>Functionality of model</b>	No model developed	Primitive model. Not function	Model partially functioning	Model completely functioning	5	
<b>Specificness to research question</b>	Not yet get to the research question	Start looking at research question			3	
<b>Clarity of status description</b>	No progress description	Unclear progress and future work	Progress and future work clearly stated		3	
				<b>Total</b>	15	

**Appendix II: Project Report Grading Rubrics**

General Quality of the Report	Grammar, format, articulation, structure, flow...	_____/3
Aim and Objectives	Articulation clearness	_____/3
Significance of the Problem	Safety, health, economy...	_____/4
Scope and Complexity of the Project	Project cannot be trivial	_____/4
Realness and Description of the Model	Dimensions, properties of materials, parameters of the system...(you may consider ways to validate the model and include the validation)	_____/8
Documentation and Correctness Technical Matters (analysis/design should be based on physics laws and engineering knowledge)	Appropriateness and correctness of equations, calculation, deduction, conclusion, etc.	_____/10
Graphical Aid Effectiveness	Figures, diagrams, and tables	_____/4
Team Collaboration	Distributed load, collaborative team, meaningful contribution...	_____/4
Total		_____/40