

Audio Signal Processing Studio Remote Lab for Signals and Systems Class

Hai Ho and Florian Misoc

Kennesaw State University, Southern Polytechnic College of Engineering and Engineering Technology

Abstract

In this paper, an innovative approach to teach audio signal processing is presented, and the associated lab apparatus is described. This method has the feel of real-time hardware lab, with the added benefit of enabling online learning. Usually, the traditional labs for Signals and Systems courses consist of MATLAB or Labview batch simulation exercises. While this approach is essential, it doesn't achieve the experience of watching signals and spectrum floating in real-time on the oscilloscope's screen. The proposed approach is based on building an audio signal processing studio using Simulink (laptop) with external input from sources such as microphone, electric guitar, and a digital music files. The course includes a large section covering audio signal characteristics, special effects such as reverberation, distortion and flanger, and noise filtering. It enables distance learning because the only required lab hardware is the computer system and software.

Keywords

Signals and systems, remote lab, audio signal processing, sound effects

I. Introduction

Audio signal processing applications are ubiquitous as they are found in consumer products at work, home, and on-the-go, such as, smart phones, tablets, home and car entertainment systems, head phones with active noise cancellation, speakers, gaming, and various human interface (HMI) devices. The recent AES (Audio Engineering Society) trend report¹ stated that signal processing applications in audio systems have grown enormously in recent years. The consumer and professional marketplace have been driving demands for higher audio quality, especially with more consumer-ready DSP hardware available. Some examples of audio related products are home and car entertainment systems, MP3 players, smart phones, head phones, and musical instruments. These trends motivate more focus on teaching the subject of audio signal processing in undergraduate classes such as Signals and Systems. Here, some of the fundamental voice and music audio processing concepts such as delay, reverb, distortion, flanging, filter, and equalization can be taught. Furthermore, a set of laboratories can be accommodated to make the learning experience meaningful. In the Engineering Technology curriculum, most technical courses are taught with both lecture and hands-on lab components.

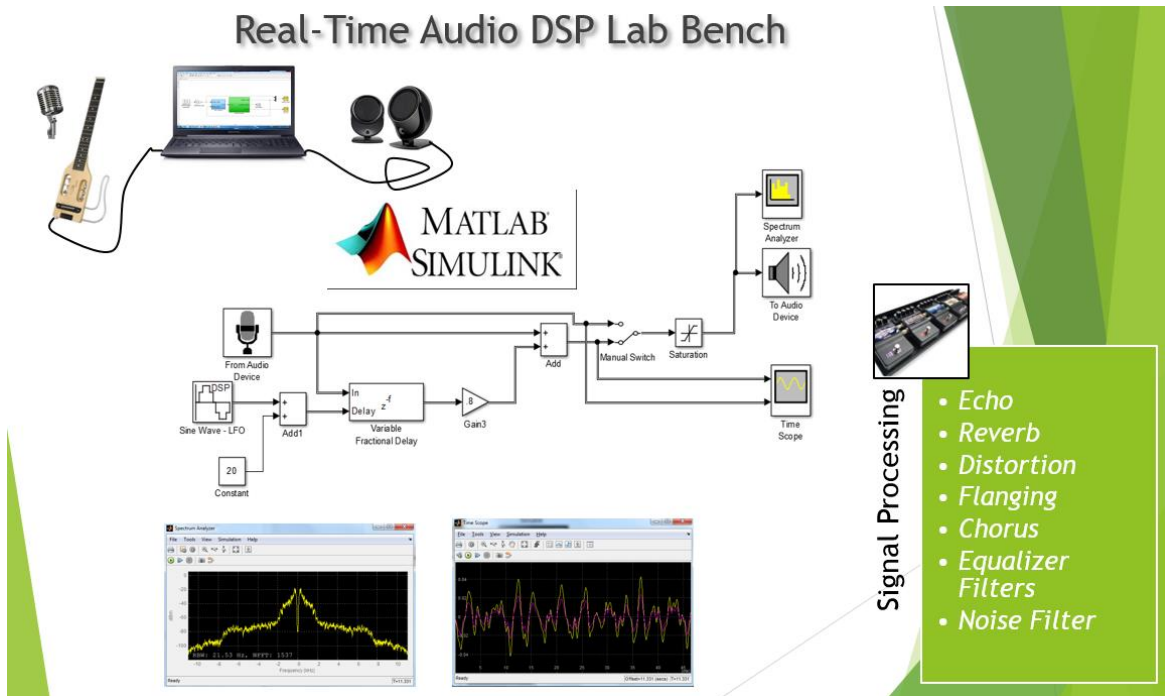

Figure 1. Portable audio signal processing lab system.

The lab setup for audio signal processing proposed in this paper, is a portable system that enables students to conduct the labs on or off campus, while experiencing meaningful hardware and real-time like effects of signal processing. The system is shown in Figure 1, and is called the real-time audio DSP studio (RTAS). It mimics a digital audio workstation (DAW) that professional sound engineers use. It consists of a computer/laptop that is loaded with Matlab/Simulink and DSP toolbox, optional input devices such as microphone or a music instrument such as electric guitar that plugs into the audio input of the computer, and the optional external audio speakers. These external devices provide enhanced lab experience, but are not required since students can use music/voice files loaded on the hard disk drive and laptop built-in speakers. In either case, the lab system is portable and can be set up anywhere that is convenient for each student. Hence, this overcomes the common obstacle associated with teaching engineering on-line, and distance learning courses (hybrid format) where lab experiments are conducted on campus.

In this paper, a course syllabus is proposed, including a section that covers the fundamentals of audio signal processing, a series of laboratory exercises, and the portable/remote lab system RTAS. This subject area has been previously identified as the key area to be covered in Signals and Systems course². This curriculum was implemented successfully at the local university and results are reported.

II. Syllabus Section for Signals and Systems Class

The standard syllabus and content of the Signals and Systems course are very well established and usually reflected by the table of content of textbooks such as by Ulaby and Yagle³. It is

advisable to teach audio signal processing and laboratories as part of the applications section, preferably after students have learned the core concepts such as filtering, the Fourier transforms, impulse response, and the Laplace transforms. The materials can be covered in 2-3 weeks to include basic audio signal processing concepts as shown in Table 1.

Lectures	Lab Exercises
1. Introduction to DSP Audio Applications	Lab 1. Setting up Simulink RTASP
2. Difference Equation	
3. Sound Effects:	
3a. Delay	Lab 2 . Common sound effects
3b. Reverb	
3c. Distortion	
3d. Flanging	Lab 3. Advanced sound effects
3e. Combination	
Filtering:	
Noise Filtering	Lab 4. Comb filters and equalizers
Graphic Equalization	

Table 1. Audio signal processing syllabus section

To begin, students learn about myriads of audio signal processing applications in both consumer and professional products. Since the basic building block of sound effect is a delay element, it is fitting to introduce students to difference equations and basic concept of digital filter using delays techniques. Then, students start learning about the various sound effects and how to generate them using the RTAS platform.

2.1 Setting up the Simulink RTAS

The first step is to build a platform capable of reading the input sound and play it out to the output speaker. This is the objective of the first lab experiment, where students are asked to build the Simulink diagram as shown in Figure 2. The top input sound source is the “From Audio Device” microphone icon, which can be the built-in microphone, external microphone, or an electric guitar using the audio adaptor which is plugged into the audio port of the computer. The second input source, shown below, is a pre-recorded audio file in the form of .mp3, .wav, or any other format supported by MATLAB. The output blocks are made up of the speaker, the spectrum analyzer, and time scope. The speaker provides the audio feedback while the analyzer and scope provide the real-time display of the signal’s spectrum and time trace, as shown in Figure 2. The digital filter block in the middle is the processing block that will later be implementing reverb, flanging, etc. In this first lab, the instructor can provide a pre-designed notch/peaking equalizer filter that produces noticeable effects on the outputs. This diagram here should be driven with a sample rate, F_s , of 44100 or 22050 Hz, and a common frame-per-second (FPS), typically set at 1024. Once the students have built this system diagram, they can run the simulation and observe the effects of the filter on the input sound source.

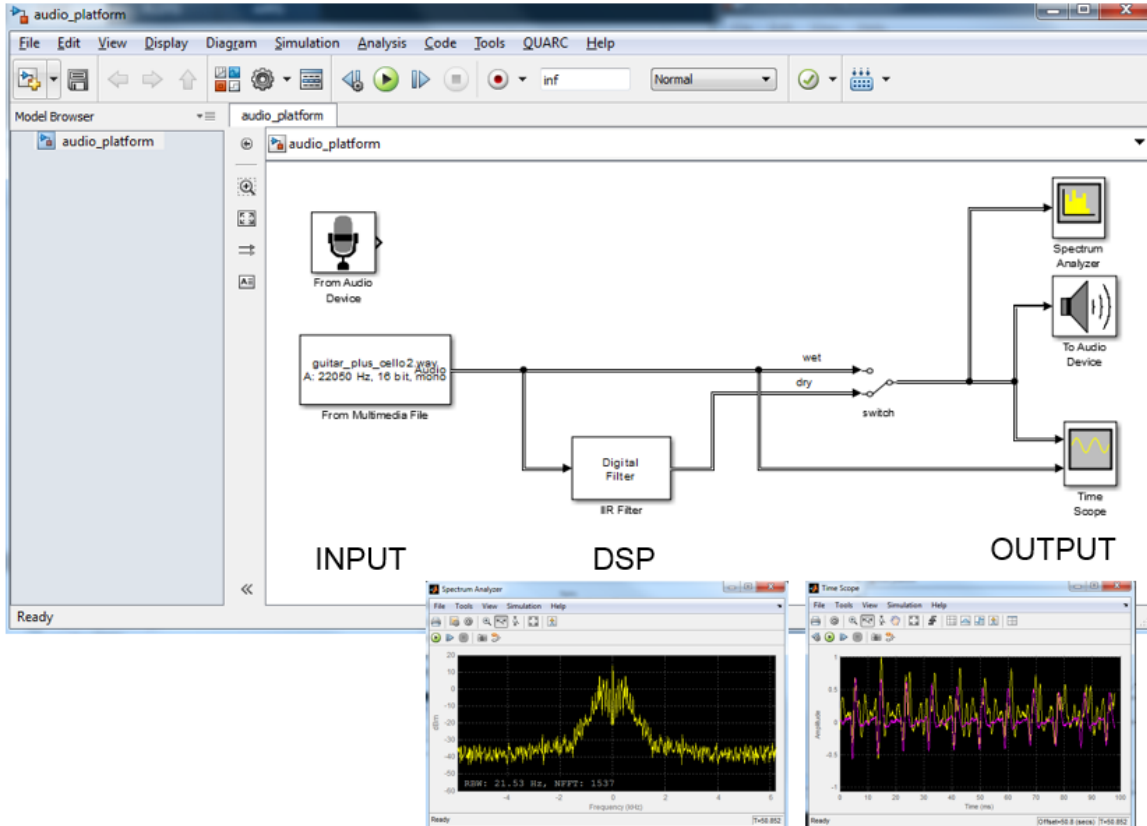

Figure 2. Simulink real-time audio signal processing (RTAS) system.

2.2 Common Sound Effects

Some of the most common sound effects found on PA systems, guitar pedals, and other instrument amplifiers are delay, echo, reverb, and distortion. An echo effect is present when there is a copy of the source signal delayed in time and then is combined with the original source. This is modeled as:

$$y(n) = x(n) + ax(n - D), \tag{1}$$

where $x(n)$ and $y(n)$ are the respective input and output signal variables, and D is the time delay amount. Since the simulation is of a digital-sampled signal, n represents the n th sample. The spacing of the samples is $T_s = 1/F_s$, where F_s in this case is 22050 Hz, which means T_s is about 45 usec. If a clearly noticeable echo effect is desired, the T_s target is 90 msec, which corresponds to frame delay of $N = 2$ shown in Figure 3. The next effect is reverberation, which is the case where there is infinite delayed copies of the source sound but with diminishing gain. This is modeled as:

$$y(n) = x(n) + ax(n - D) + a^2x(n - 2D) + a^3x(n - 3D) + \dots \tag{2a}$$

$$y(n) = ay(n - D) + x(n), |a| < 1, \tag{2b}$$

Which is simply an IIR filter, which is shown at the bottom of the diagram in Figure 3. The gain factor “a” in equations 1 and 2 represents the degree of the sound effect, the larger it is, the more pronounced the effect. This gain is implemented by the gain blocks Gain1 and Gain2 in the block diagram. The last common sound effect is the distortion that is found in rock guitar. The simplest form is clipping of the input signal. This is done by the saturation block as shown. Students can experiment with the clipping level to get varying degrees of distortion. Real world distortion can be a bit more sophisticated⁴, and can be modeled using this framework.

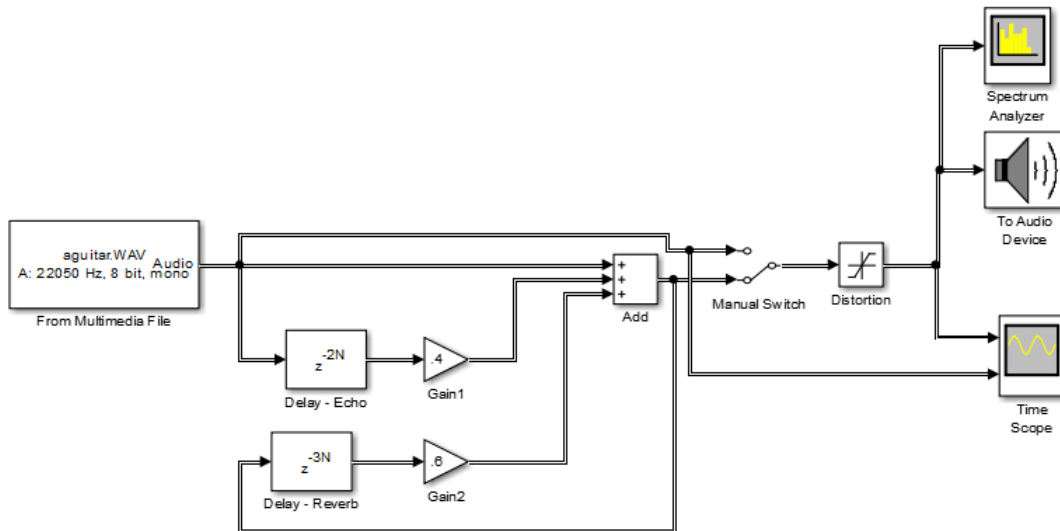

Figure 3. Common sound effect blocks

2.3 Advanced Sound Effects

The next lab aims at exploring the effect of flanging⁴, which is similar to a chorus effect where the audible output exhibits a “breathing” phenomenon which is described by a variable or modulated delay. Again, if $x(n)$ is the input signal source, then the output of a flanger can be expressed as

$$y(n) = x(n) + x(n - A[\sin(2\pi f_o n) + 1]), \quad (3)$$

The parameters A and f_o can be varied to achieve the desirable level of flanging. In recent lab session, the values of 18 and 1 Hz were used, resulting in noticeable effect. The Simulink blocks that were used to implement (3) is the low frequency oscillator (LFO) sine wave and the fractional delay blocks, as shown in Figure 4. The sound effect of a flanger is difficult to appreciate unless one can audibly hear it. At this point, students have built the various building blocks such as echo, reverb, distortion, and flanging, and next is the creative step of combining them to produce a unique overall effects. This is described in Figure 5, system diagram that can be readily implemented in Simulink with additional controls such as switches and sliders. This creative step is akin to what sound engineers do on the DAW.

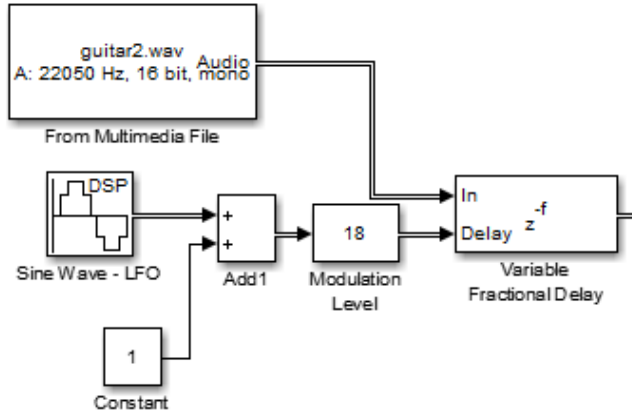

Figure 4. Implementation of flanger effect

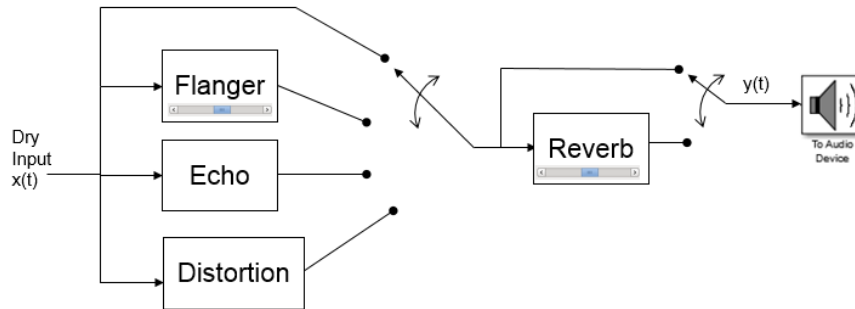

Figure 5. Combining the sound effect blocks together

2.4 Filtering and Equalization

In many commercial applications, the signal of interest is contaminated by noise, therefore, needs to be filtered. In the Lab 4, students were given a sound byte with a 1.3KHz harmonic noise on it. When the sound is played, one can readily hear the tone. The spectrum is shown in Figure 6, left image. The next step was to design an IIR notch filter to filter out this tone. MATLAB command line function Butter(...) was used to design the filter and then implement it in Simulink. The results sought were the eliminating of the audible tone and observing the disappearance of the tone in the spectrum shown in Figure 6, right image. This simple exercise had given many students the appreciation of filtering since they could hear and see the results.

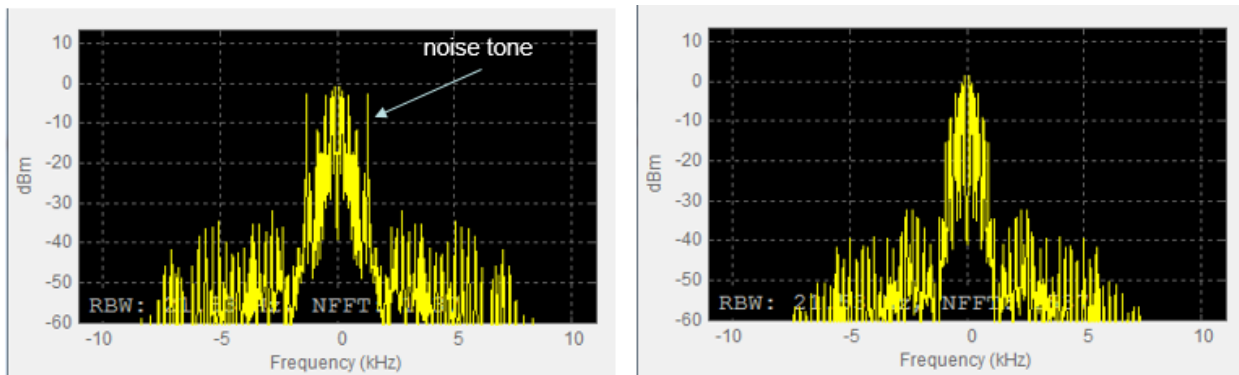
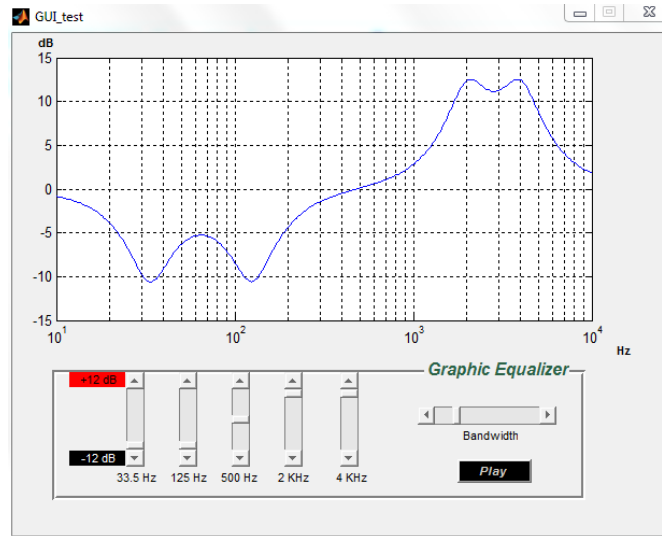

Figure 6. De-noising audio signal example spectrum

Graphic equalization is one of the most popular application because it is found in virtually every stereo system. It is based on a bank of cascaded notch and peaking filters to form a n-band graphic equalizer⁵. In Figure 7 it is shown the 5-band GUI equalizer that students designed. They can alter the slider controls and watch the frequency response changes, and then play the music to hear the effect. This lab is rather lengthy and would require more than the one session time allotted to complete the experiment.



2.5 Implementation

This curriculum was implemented at a junior/senior Signals and Systems class at Southern Polytechnic State University this past year. A survey was given at the end of the class. Each survey question asked for a response between 1 (strongly disagree) to 10 (strongly agree). The results indicated that the large majority of the students enjoyed and benefited from the audio signal processing topic and RTAS labs. The one data point that stood out was the low 50% agreement rate on their ability to do all these labs remotely. This question was misconstrued as performing the labs independently and without supervision, which would not be the case with distance learning format, where the instructor would be available to give instructions and guidance online.

Questions	Mean	7 or higher
1. The RTAS platform and labs enabled me to learn the filtering signal concepts more easily than pure simulation.	9.1	100%
2. I can do all RTAS labs remotely if ECET 3620 were on-line class	5.5	100%
3. RTAS feels like a real lab with scope and I/O devices	9.2	50%
4. I recommend continue using the RTAS lab bench for this class	9.5	100%

Table 2. Class survey results

III. Summary

An innovative approach to teach introductory signal processing was presented, with the goal of achieving the meaningful laboratory learning experience, method well suited for online and hybrid teaching. This new teaching method makes online and distant learning attractive while maintaining rigorous hands-on quality. This was achieved through a set of audio signal processing topics and lab exercises based on the RTAS Simulink platform. This platform is truly portable, as it requires only the laptop computer and MATLAB software, yet students experience the design effects, audibly perceived and visually displayed on the virtual real-time scope and spectrum analyzer. Additional devices such as microphone, electric guitar, and speaker can be used to enhance the experience, but are not required. The syllabus of this set of labs was outlined, including details on how to cover the technical topics and the corresponding lab exercises. Based on preliminary data, and to student feedback, this method of teaching Signals and Systems course is superior the traditional methods, facilitating the on-line teaching with hands-on quality labs.

References

1. _____, "Technology Trends in Audio Engineering," Journal of Audio Engineering Society," Vol. 60, No. 1/2, 2012 January/February.
2. Lee, Edward A. "Designing a relevant lab for introductory signals and systems." Proc. of the First Signal Processing Education Workshop. 2000.
3. Ulaby, F. and Yagle, A., ed. Engineering Signals and Systems. NTS Press, 2013.
4. Zölzer, Udo, ed. DAFX: digital audio effects. Vol. 1. New York: Wiley, 2002.
5. Bristow-Johnson, Robert. "The equivalence of various methods of computing biquad coefficients for audio parametric equalizers." Audio Engineering Society Convention 97. Audio Engineering Society, 1994.

Hai Ho, Ph.D., NPDP

Dr. Ho has diverse experience in both academia and industry. He has worked in various industries, including, hard disk drives, RFID smart card/reader, aerospace, robotic libraries, and consumer electronics. He was formerly the Vice President of Engineering and Product Development at Newell Rubbermaid and HID Global, where he led multi-discipline team consisting of Mechanical, Electronics, Embedded Firmware, Compliance, Software, Program Management, Test, Industrial Design, and Sustaining. He received his B.S. (1988), M.S. (1989) and Ph.D. (1994) in Electrical Engineering at the University of Colorado.

Florian Misoc, Ph.D., P.E.

Dr. Misoc earned a Ph.D in electrical engineering from Kansas State University, in 2007, a M.S. in engineering technology from Pittsburg State University, in 1999, and a B.Sc.in physics from the University of Bucharest-Romania, in 1989. He is an Associate Professor of electrical and computer engineering technology, at Kennesaw State University, in Marietta GA, USA. His research areas of interest are: renewable energy systems, power electronics and distributed energy systems. Dr. Misoc is a Registered Professional Engineer in the state of Arkansas, and he is a reviewer for the IEEE Journal of Electric Power Components and Systems.