

Design and Build: Teaching Cognitive Skills Through Tool Use

Eric Pappas¹, Robert Prins²

Abstract - The six-semester 10-credit *design and build* studio sequence in the School of Engineering at James Madison University focuses on product and process design. Instruction in the design sequence is developmental (using Bloom’s Taxonomy) and focuses on four contexts in sustainability: environmental, social, technical, and economic. The principle objective of this effort is to improve engineering students’ thinking skills and problem solving abilities (as well as tool use skills) through brief design projects that *target and enhance specific cognitive processes employed in the construction process experience* (e.g. visual imagery and spatial awareness, prediction, concentration, shape / form / size / proportion, and reasoning in conceptual thought). This paper and presentation address the tool training required to prepare students to function in the studio, the projects we assigned to target and develop specific cognitive processes, and relevant results of our first survey of freshman engineering students following the first design and build module.

Keywords: Design, Tool Use, Cognition, Design and Build

INTRODUCTION

In August 2008, James Madison University (JMU), traditionally known as a liberal arts university, enrolled its first engineering students into a unique engineering product and process design program focused on *sustainable design*. A noteworthy component of this integrated design and build program is the six semester 10-credit design laboratory sequence that stretches from the sophomore year to graduation, and includes significant project work. We present a divergence from the generally accepted approach to sustainability (normally referred to as “sustainable engineering” or “environmental sustainability”) and include instruction in creating sustainable societies.

Design instruction in our design sequence focuses on sustainability in four contexts: *environmental, socio-cultural, economic, and technical*. Students learn to design (and re-design) for sustainability in all contexts and are required to build (or model) their designs. Throughout the program, students are required to design or re-design products and processes that are subject to sustainability criteria we developed for student projects. Throughout the design program, in addition to design instruction and practice, students receive group and individual instruction in the use of machine tools (e.g. band saw, hand tools, drills, lathe, etc.).

Our approach to teaching design includes instruction in critical thinking practices—*the intentional and directed cognitive processes and habits that foster effective thinking*. This approach includes projects that require students to physically construct their designs as part of the design iteration process. Our assertion is that critical thinking in combination with hands-on project experience inspires better design.

This paper describes the first of three stages of initial research into instruction in tool use and cognition, an almost entirely undocumented area of engineering research. Our results are general but encouraging, and research continues each semester. Our targeted second stage assessment is nearly complete and will be presented in an upcoming paper. This effort is funded by National Science Foundation IEECI Grant #0933948 and National Science Foundation CCLI Grant # 0837465.

LITERATURE REVIEW

There is very little in the formal engineering literature addressing cognitive process development related to hand or machine tool use. Much of the research on tool use and cognition is found in the psychology and education literature.

¹School of Engineering, James Madison University, Harrisonburg, Virginia, PappasEC@jmu.edu

²School of Engineering, James Madison University, Harrisonburg, Virginia, PrinsRJ@jmu.edu

Cognition and tool use research in engineering, outside of using computers as cognitive tools, [Zydney, 14; Newstetter, 8] is a largely unexplored area; however, some authors provide research into the nature of tool-use related creativity, design skill and tool-use improvement, and the assessment of students' improvement in problem solving skills through cognitive tool use.

As an interdisciplinary and alternative approach to learning styles, Keller and Keller note that visual imagery and physical virtuosity, rather than verbal logic can serve as legitimate areas of cognitive inquiry, in this case, the study of blacksmithing. [Keller, 5] Malicky, et al. focus on inductive learning in their University of San Diego machine shop class in mechanical engineering. [Malicky, 6] Though the use of hand tools like the miter saw, drill press, sander, and band saw in active learning projects, the authors surmised that students constructed more theoretical knowledge structures than with instruction that did not focus on inductive problems.

In their description of the phases through which industrial engineering endured, Bailey and Barley note several facts related to tool use and cognition. [Bailey, 1] Of particular relevance to this paper is their suggestion that in the current industrial engineering evolutionary scheme, the study of ergonomics is giving way to interests related to risk analysis, decision making, and cognitive psychology in shop practices and factory methods.

Much of the research on tool use and cognition emerges from the concepts "situated learning" or "situated cognition," which Brown defines as "that knowledge is situated, being in part a product of the activity, context, and culture in which it is developed and used." [Brown, 2, p.32] The authors suggest that the use of the tool and the attendant setting are inseparable as far as cognitive processes are concerned, whether the tools be chisels and saws, or computers. The authors further suggest that "learning in a domain [a field of study with common characteristics-Ed.] enables students to acquire, develop, and use cognitive tools in authentic domain activity" (p.39); that is, using tools increases cognitive activity and ability. Salomon writes of his disagreement with Brown (above), and argues that, the interaction between a human being and an intelligent tool (computer) results in a favorable "cognitive residue" (p.5) that does not result from the interaction between a tool user and a non-intelligent tool ("situated").⁷ The "cognitive residue" that results in these situations is that the use of intelligent tools may result in thinking skills being transferred to other dissimilar situations (but notes that too little research has been done in this area).

Vygotsky's notion that understanding is social in origin, [Vygotsky, 14] argues Cole, is in direct contrast to Piaget, who claims that children develop cognitive abilities by *doing*. [Piaget, 11] Dewey suggests that *both* social and individual experiences produce an interweaving of biology and human experience ("doing"). [Dewey, 4] Cole and Wertsch suggest that such learning processes are "mediated," that is, that "direct action" is an indirect action, one that relies upon previous experience and incorporates it into the current action. [Cole, 3] This argument of "distributed cognition" suits well the research and contention of the current paper—that increasing cognitive ability through tool use may well be one based on students' prior experience with tools as well as the cognitive condition that results from actually using the tool. (*Distributed cognition* suggests that human knowledge and cognition are not confined to the individual, rather, they are distributed by placing knowledge of, memory, or facts, in this case, on tools in our environment.)

Pea suggests that the use of tools (as well as computers) interfaces to complex tasks and is socially constructed as well as brought about by individual differences. [Pea, 10] He notes: "By shaping nature and how our interactions with it are mediated, we change ourselves." [Pea, 9] Maravita and Iriki suggest that tool use "creates changes in specific neural networks that hold an updated map of body shape and posture... a Body Schema." [Maravita, 7, p.1] This effect would lend support to what we already know as "experience using tools" in that cognitive changes accompany repeated tool use. The author continues: "To act efficiently in space, our brain must not only localize any objects of interest in extrapersonal space but also hold a constantly updated status of the body shape and posture." [Maravita, 7, p.1] There is little doubt this factor would increase cognitive tool use through familiarity of motion and tool effect.

TRAINING FOR STUDIO WORK

Although our program includes a significant hands-on construction component, we do not assume our students arrive with the required skills. In order to prepare students for studio work, we provide initial training in the freshman engineering course (Engineering 112). Students participate in an initial introductory session (studio boot camp) and four additional sessions. Studio boot camp includes safety information as well as training in use of basic hand tools; power tool and machine tool instruction is covered in subsequent sessions. The training session takes place in the Engineering Design Studio, a purpose-built facility that includes 1200 ft² of instructional space and 600

ft² of construction space. The instructional space includes 15 large laboratory benches and can also be used for assembly tasks. The construction space contains workbenches, tools, and materials for construction.

Studio Construction Space

There are four large work benches with 3' x 7' steel clad tops in the construction space; each workbench is equipped with a vise near one of its corners. Several tools are available within the construction space including floor-mounted machine tools, hand held power tools, and hand operated tools. Our inventory of machine tools includes two combination Mill/Lathe machines, two floor mounted drill presses, a pedestal mounted 6" grinder, a band saw, and a combination belt sander / disk sander. Hand held power tools include jig saws, saber saws, battery powered and cord powered drills, Dremel tools, and belt sanders. Our inventory of hand operated tools includes crosscut saws, rip saws, miter saws, hacks saws, and sanding blocks. An assortment of hand tools and accessories such as wrenches, screwdrivers, tap and die sets, squares, punches, and drill bits are also available.

Boot Camp Description

Studio boot camps have three components: 1) safety and procedural rules, 2) tool usage instruction, and 3) tool usage exercises. Our safety rules are fairly standard:

- Do not work alone
- Report all injuries
- Use safety glasses with side protection
- Confine long hair and loose clothing, remove jewelry
- Use "fully-closed" shoes
- Do not eat, drink, or chew gum
- Keep your work area neat

In addition to these rules, we discuss responsible behavior and fire extinguisher usage and location. After the discussion of safety and procedural rules, students who wish to participate sign a standard JMU Acknowledgement of Laboratory Responsibility and Training (ALRT) form.

The tool usage instruction is typically presented as a demonstration; demonstrations are generally followed by an exercise in which each student copies the demonstrated operation. A variation to the demonstrate/copy approach occurs in the final exercise in which no demonstration is given and instructions are limited to a description of the desired finished product.

The number of students and instructors in a given boot camp session varies from four students with one instructor to nine students with one instructor. Previous sessions have included eight students and two instructors although feedback from instructors suggests that four to six students per instructor is appropriate. In the case of two instructors, the number of students must be limited to eight due to tool and workspace availability.

Boot Camp Tool Instruction

We attempt to cover tool operations required for simple construction based on our best estimate of what tools will be most useful. Three topics are included in boot camp: cutting with hand saws, drilling, and fastening.

Cutting with hand saws

This topic includes layout, clamping, cutting, and inspection. Three types of saws are covered: crosscut saw, miter saw, and hacksaw. In the first demonstration, the layout, clamping, location of saw blade, and cutting stroke are described in detail; in later demonstrations, these steps are performed with a less detailed narrative. Details covered in the first demonstration include use of a tape measure, marking a distance using two intersecting marks, using a square to draw a line at the marked distance, clamping the work piece with consideration for tool path, selecting a starting location for the saw blade relative to the marked line based on saw kerf, starting the cut, proper saw stroke, and finishing the cut. After the sample piece is cut, it is inspected for length and for squareness. Students then worked in groups of two to repeat the exercise with each student generating a sample.

The second demonstration is essentially a repeat of the first, but with the aid of a miter box and miter saw. For the third demonstration, the miter box is used again, this time to generate a 45 degree cut. The material used in the first three demonstrations is nominal 1" x 3" pine. For the final saw demonstration, featuring the hacksaw, students cut samples from their choice of metal stock in the studio stock rack (various sizes of aluminum and steel bar).

Drilling

This topic includes layout, punching, clamping, and drilling. Two types of drills are covered: the bit brace and the hand drill. For these demonstrations, each step is shown and described, but in less detail than the first cutting demonstration. Details covered include marking the desired hole center, using a hammer and center punch to create a divot at the desired center point, drill bit selection, operation of a drill chuck, and proper drilling technique.

Fastening

This topic features the attachment of two nominal 2"x4" boards using screws. Although no demonstration was given for this topic, a brief discussion of screwdrivers and pilot hole sizing for screws based on screw shank size was included. Students are then required to construct a butt joint using two precut pieces of nominal 2"x 4" pine.

Additional Instruction Sessions

Four additional instruction sessions are included in Engineering 112 as part of the laboratory experience. These sessions cover setup and operation of drills, various saws, and a "Smithy" machine that can be configured as a lathe, mill, or drill press. Each session lasts approximately 30 minutes and includes some hands-on work by the students, but at a less intense level than the boot camp. Sessions typically include one instructor and approximately ten students. A project is assigned after students are familiarized with drills and saws; a second project is assigned after the lathe session. No project associated with the mill is assigned in the introductory course.

Drills and taps

Students are introduced to power drilling operations and tapping operations through a pre-lab reading assignment and a live demonstration. The pre-lab reading consists of nine pages of images and brief text describing the tools, nomenclature, and operations related to drilling and tapping. Topics include:

- hand drills
- drill press
- drill bits
- threads
- taps and dies
- screw head styles
- counterbores and countersinks

During a 30-minute laboratory session, students observe live demonstrations of drilling and tapping procedures, and then participate in the drilling and tapping of a hole in a piece of aluminum stock. Demonstrations include:

- safety issues with drilling
- use of battery and corded hand drills
- operation of keyed and keyless drill chucks
- drill press operation
 - speed selection
 - center drilling
 - through drilling
 - counterboring
 - countersinking
- hand tapping
 - tap selection
 - tap drill selection
 - tapping operations

The tapping demonstration is followed by a group exercise in which students work as a team to generate a tapped hole. Students work in pairs of two on one of the following hole tapping related tasks:

- tap selection from tap and die kit
- tap drill size selection and retrieval from drill index
- tap drilling of aluminum stock
- tapping of hole
- verification of process by running the appropriate screw (retrieved from stock) through the hole.

Saws

Students are introduced to saws and their operation through a pre-lab reading assignment and online quiz, as well as a live demonstration. The pre-lab reading consists of eight pages of images and brief text describing the tools, nomenclature, and operations related to saws. Topics include:

- saw blades
- jig saws
- sabre saws
- band saws

Students are required to take a short online quiz to encourage completion of the pre-lab reading assignment.

During a 30-minute laboratory session, students observe live demonstrations of saw operations; demonstrations include:

- safety issues with saws
- use of hole saws
 - assembly of pilot drill, hole saw, and arbor
 - typical operation
 - avoidance of splintered “breakout”
- jig saw
 - safe blade changing
 - blade selection
 - manipulation of
 - orbit control
 - speed control
 - blower
 - use as a pattern saw for internal and external profiles
 - use as cutoff saw
- sabre saw
 - safe blade changing
 - manipulation of speed control
 - use as cutoff saw
- band saw
 - operation of feed control
 - demonstration of automatic shut-off switch
 - clamping and cutting of stock

During the saw demonstration, two to three students have the opportunity to participate in using the jig saw or sabre saw as a cut-off saw for either wood or steel. Although time does not permit all students to operate each saw during the demonstration session, it is valuable for students to observe their peers struggle but succeed with saw use.

Lathe

Students are introduced to lathe setup and operation through a pre-lab reading assignment and online quiz, as well as a live demonstration. The pre-lab reading consists of nine pages of images and brief text describing the tools and nomenclature related to lathes as well as lathe setup and operation. Where practical, the images used were of the actual tool that students use to complete their projects. Topics include the following:

- personal safety
- nomenclature
- operation
 - chuck speed control
 - manual control
 - automatic feed control
 - tool post usage
 - tail stock usage
 - facing
 - turning

Students are required to take a short online quiz to encourage completion of the pre-lab reading assignment.

During a 30-minute laboratory session, students observe a live demonstration of lathe operations including:

- mounting the chuck
- mounting the compound tool post
- proper chuck rotation direction
- mounting the blank part in chuck
- facing the part using manual feed
- installing the center drill in tailstock
- center drill part
- mounting the part for turning between centers
- turning using power feed

During the demonstration, one or two students participate in determining an acceptable gear combination for auto feeding, and adjust the lathe settings to that gear combination. This serves to demonstrate to the group that the gear selectors can be difficult to operate, but success is possible.

Mill

Students are introduced to mill setup and operation through a pre-lab reading assignment and a live demonstration. The pre-lab reading consists of six pages of images and brief text describing the tools and nomenclature related to mills, as well as mill setup and operation. Where practical, the images used were of the actual tool that students use to complete their projects. Topics include:

- personal safety
- nomenclature
- setup
 - vise installation and alignment
 - tool holder installation (collet or chuck)
 - collet and drawbar operation
 - milling with end mills

During a 30-minute laboratory session, students observe a live demonstration of mill operations including:

- mounting and alignment of vise
- installation of tool holder
- clamping of end mill in collet
- proper rotation direction of end mill
- mounting of work piece in vise
- milling with autofeed

During the demonstration, one or two students participate in determining an acceptable gear combination for autofeeding, and adjust the settings to that gear combination.

STUDENT PROJECTS

Students participated in three construction projects in the introductory course: 1) a block assembly “widget,” 2) a lathe part, and 3) an open ended design project. The level of specification is reduced with each assignment. The widget assembly is completely specified, the lathe part requires the students to perform certain operations, but the final product is unspecified. The open-ended design project has broad requirements, but no specifications. The assembly and lathe part assignments are described below, the open-ended design project will be described in a subsequent article.

Widget

The widget assembly is assigned after students participate in the drill and saw demonstrations described above. The assignment is shown in Figure 1 below.

ITEM NO.	DESCRIPTION	QTY.
1	TOP PLATE 1/2" ALUMINUM	1
2	BASE PLATE 1/2" ALUMINUM	1
3	1/4-20 x 5/8" SOCKET HEAD CAP SCREW, BLACK OXIDE FINISH	1
4	5/16" WASHER, ZINC FINISH	1
5	5/16-24 x 1" HEX HEAD CAP SCREW, ZINC FINISH	1
6	M6X1 x 22MM FLAT HEAD CAP SCREW, STAINLESS STEEL	1

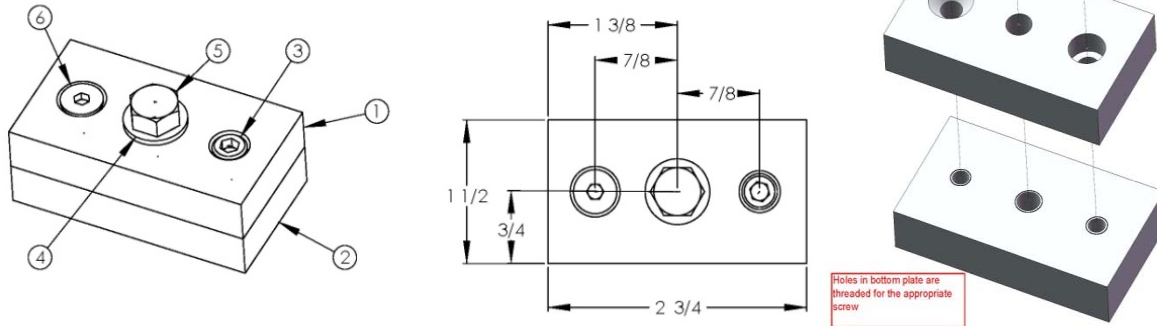

Figure 1: Build assignment associated with tool usage unit focused on drilling and tapping

Aluminum stock of the proper dimension was available so that students needed only to cut two blocks to length. The fasteners used were selected to expose students to significant variety; the assembly requires standard coarse thread, standard fine thread, and metric fasteners. Each fastener has a different style head: flat head, socket head, and hex head. Each fastener also has a different material finish: stainless, zinc, or black oxide. Students must perform three tapping operations that require different taps and tap drills, and must use the drill press to drill through holes as well as perform counterbore and countersink operations. Accurate layout methods are rewarded with an assembly that can be screwed together. Figure 2 shows a completed assembly.

The cognitive processes targeted in the *Widget Exercise* include 1) reasoning in procedural thought, 2) concentration, and 3) eye-hand coordination.

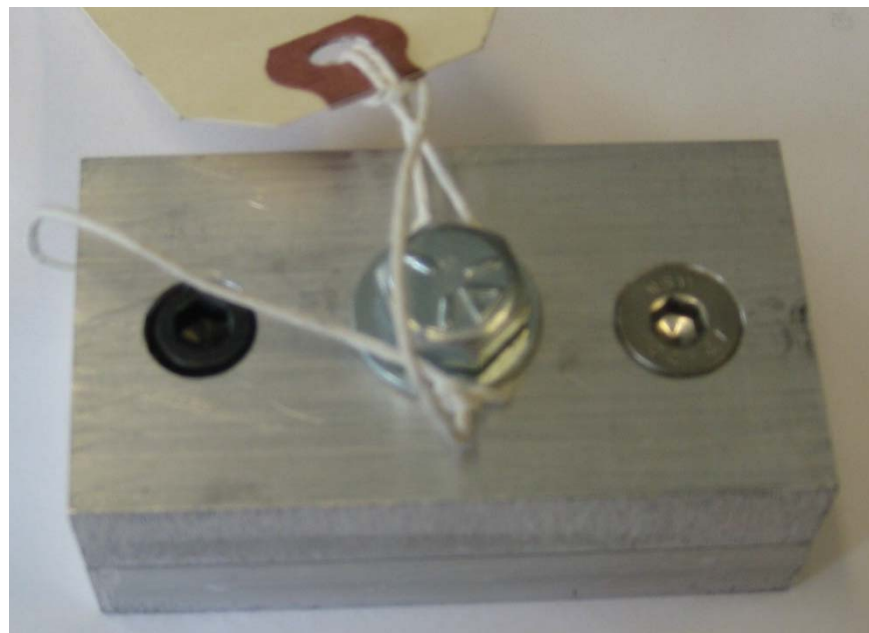

Figure 2: Completed widget assembly

Lathe Part

The lathe assignment allows students to produce a part of their own choosing as long as the part demonstrates facing and turning operations. A score of 75% is proposed for a cylindrical part that has been faced and turned. In order to achieve a higher score, students need to add details such as tapers, grooves, or holes as well as a stated purpose or use. Figure 3 shows partial results of this assignment.

The cognitive processes targeted in the *Lathe Part Exercise* include 1) prediction of shape / size / form / proportion, 2) visualization and 3) assessing material properties.

All students chose to add details to their lathe part. Although the results varied in quality, students demonstrated the ability to perform turning and facing operations on the lathe. We considered requiring students to provide a drawing of their part, or to pre-specify their part but chose instead to allow the students time to familiarize themselves with the equipment using this “discovery” approach.



Figure 3: Examples of student response to lathe assignment

FEEDBACK AND ASSESSMENT

Boot Camp Experience

To help us evaluate the boot camp sessions, we asked students if boot camp increased their confidence in hand tool usage. In response, 55% of students agreed that the boot camp session increased their confidence with hand tools with 40% strongly agreeing with this statement. We were uncertain what the benefit of boot camp would be since we teach tool use at a basic level. It is interesting to observe that 40% of students indicated strong agreement that boot camp increased their confidence in hand tool usage.

Widget Assembly

Each assembly was assessed for completeness, proper fit of screws (below surface of top plate), use of proper tool bits to create counterbores and countersinks, and completeness of threads. The grading formula is shown below and is based on a 100 point scale:

- -2.5 per screw for above flush
- -5 for using drill as counterbore or countersink
- -10 for no counterbore
- -10 for threaded hole in top plate (should be through hole)
- -5 (max) for incomplete threads in tapped holes

The grading scale is set up so that students who hand *something* in score a significant amount of points regardless of quality. This reflects our primary goal of having students interact with the tools rather than achieve any level of mastery in the first exercise. Out of 76 students, 74 turned in an assembly, scores for completed assignments ranged from 88% – 100%; the average score was 96%. The final exam included six matching questions related to the recognition and naming of various tools, tool bits, and part features associated with this unit. Students scored a collective 79% on these questions.

Lathe Part

The lathe assignment was assessed for inclusion of the required features and inclusion of optional features. Inclusion of all required features was worth 75/100 points; additional points were awarded based on instructor perception of the difficulty, creativity, and utility of optional features. Note that all students added optional features. Out of 76 students, 73 turned in a lathe part; scores for completed assignments ranged from 80% -100%, and the average score was 96%.

The final exam included three questions related to lathe control lever positioning and six questions related to recognition of major lathe parts. Students scored a collective 85% on the control lever questions, and a collective 98% on the lathe part recognition questions.

Student Attitudes toward Construction Projects

Students were given a course survey at the end of the semester that revealed student attitudes toward the tools training and practice received in Engineering 112. When asked which part of the course they liked the best, 26 out of 72 student responses included references to the assembly assignment, build projects, working in the shop, or working with machines. Three students specifically referenced the lathe in their response. This suggests that many students have developed a positive attitude toward working with machines such as those required for these assignments. Further support for this assertion is that 99% of students indicated some level of agreement with the statement: “The design project and tools training were valuable learning experiences,” with 68% of students indicating strong agreement. On the negative side, three students indicated that their greatest dislike was that there were too few tools relative to the number of students. In other open ended responses, one student indicated that learning to use the tools was hard.

CONCLUSION

The use of hand and power tools was introduced in an introductory engineering course through training and projects. In addition to providing the operational details required for adaptation to other curricula, the authors provide evidence that tool usage can be considered a legitimate area of cognitive inquiry. This experimental research requires additional wide-ranging exploration and assessment before dissemination of specific instructional methodologies can be undertaken. Efforts to assess targeted cognitive processes are underway at this time.

Student response to this approach was positive. Students exhibited high levels of engagement in the tool usage projects, and some students (≈35%) considered such activity to be the high point of the course. Further evidence of student engagement can be seen in the variety of the open-ended lathe projects. Nearly all students (99%) agreed that the design project and tools training were valuable learning experiences, with 68% indicating strong agreement.

We intend to move forward with this approach in three ways: 1) refine the curriculum and projects described in this paper, 2) develop new projects for more advanced courses, and 3) further explore the connection between design/build activities and cognitive development.

REFERENCES

- ¹Bailey, D. and S. Barley. "Return to Work: Toward Post-industrial Engineering." *IIE Transactions* 37, 737-752. 2004.
- ²Brown, S., Collins, A., and P. Duguid. "Situated Cognition and the Culture of Learning." *Educational Researcher*, 32-42, January-February, 1989.
- ³Cole, M. and J. Wertsch. "Beyond the Individual-social Antimony in Discussion of Piaget and Vygotsky." *Human Development*, 39, 250-256, 1996.
- ⁴Dewey, J. *Experience and Education*. New York: Macmillan. 1938.
- ⁵Keller, C. and J. Keller. *Cognition and Tool Use: The Blacksmith at Work*. New York: Cambridge University Press. 1996.
- ⁶Malicky, D., Kohl, J., and Huang, M. "Integrating a Machine Shop Class into the Mechanical Engineering Curriculum: Experiential and Inductive Learning." ASEE National Conference, 2007.
- ⁷Maravita, A. and Iriki, A. "Tools for the Body (schema)" *TRENDS in Cognitive Sciences*, Vol.8 No.2. February 2004.
- ⁸Newstetter, W. and J. Kolodner. "Learning to Change the World: A Case Study of a Mechanical Engineering Design Course." EduTech Institute, Georgia Institute of Technology. 1995.
- ⁹Pea, R. "Beyond Amplification: Using Computers to Reorganize Human Mental Functioning." *Educational Psychologist*, 20, 167-183. 1985.
- ¹⁰Pea, R. in *Distributed Cognitions: Psychological and Educational Considerations*. (Gabriel Salomon, editor). New York: Cambridge University Press. 1993.
- ¹¹Piaget, J. *Structuralism*. New York: Basic Books. 1970.
- ¹²Salomon, G., Perkins, D., and T. Globerson. "Partners in Cognition: Extending Human Intelligence with Intelligent Technologies." *Educational Researcher*, 2-9, April 1991.
- ¹³Vygotsky, L.S. *The Collected Works of L.S. Vygotsky: Vol. I, Problems of General Psychology*. New York: Plenum. 1987.
- ¹⁴Zydney, J. "Cognitive Tools for Scaffolding Students Defining an Ill-structured Problem." *Journal of Educational Computing Research*, Vol. 38(4) 353-385. 2008.

Eric C. Pappas

Associate Professor, School of Engineering, James Madison University, Harrisonburg, Virginia.

Robert Prins

Assistant Professor, School of Engineering, James Madison University, Harrisonburg, Virginia.